



Internal Use Only

<http://biz.lgservice.com>

Multi V Air Conditioner SVC MANUAL(Exploded View)

**MODEL : ARNU07GTU*2
ARNU09GTU*2
ARNU12GTU*2
ARNU18GTT*2
ARNU24GTT*2**

CAUTION

Before Servicing the unit, read the safety precautions in General SVC manual.
Only for authorized service personnel.

1. Specification

Type			1Way ceiling cassette (art type)		
Model		Unit	ARNU07GTUR2	ARUN07GTUC2	ARUN07GTUA2
Cooling capacity		kW	2.2	2.2	2.2
		kcal/h	1,900	1,900	1,900
		Btu/h	7,500	7,500	7,500
Heating capacity		kW	2.5	2.5	2.5
		kcal/h	2,200	2,200	2,200
		Btu/h	8,500	8,500	8,500
Casing			Galvanized steel plate	Galvanized steel plate	Galvanized steel plate
Dimensions(WxDxH)	Body	mm	860x450x132	860x450x132	860x450x132
		inch	33.8x17.7x5.2	33.8x17.7x5.2	33.8x17.7x5.2
	Front panel	mm	1,100x500x34	1,100x500x34	1,100x500x34
		inch	43.3x19.7x1.3	43.3x19.7x1.3	43.3x19.7x1.3
Coil	Rows x Columns x FPI		2x12x18	2x12x18	2x12x18
	Face area	m ²	0.16	0.16	0.16
Fan	Type		Cross flow fan	Cross flow fan	Cross flow fan
	Motor output x number	W	30	30	30
	Running current	A	0.18	0.18	0.18
	Air flow rate(H/M/L)	CMM	8.2/7.3/6.4	8.2/7.3/6.4	8.2/7.3/6.4
		cfm	289.5/257.7/225.9	289.5/257.7/225.9	289.5/257.7/225.9
	Drive		Direct	Direct	Direct
Motor type		BLDC	BLDC	BLDC	
Temperature control			Microprocessor, Thermostat for cooling and heating	Microprocessor, Thermostat for cooling and heating	Microprocessor, Thermostat for cooling and heating
Sound absorbing thermal insulation material			Foamed polystyrene	Foamed polystyrene	Foamed polystyrene
Safety device			Fuse	Fuse	Fuse
Pipe connections	Liquid side	mm(inch)	Ø6.35(1/4)	Ø6.35(1/4)	Ø6.35(1/4)
	Gas side	mm(inch)	Ø12.7(1/2)	Ø12.7(1/2)	Ø12.7(1/2)
	Drain pipe(internal dia.)	mm	25	25	25
Net weight	Body	kg(lbs)	14.6(32.2)	14(30.86)	14(30.86)
Noise level(sound press, 1.5m, H/M/L)		dB(A)	32/29/26	32/29/26	32/29/26
Power supply		Ø, V, Hz	1, 220 ~ 240, 50 1, 220, 60	1, 220 ~ 240, 50 1, 220, 60	1, 220 ~ 240, 50 1, 220, 60
Refrigerant control			EEV	EEV	EEV
Power cable			CV1.5 x 3C	CV1.5 x 3C	CV1.5 x 3C
Transmission cable			CVV-SB 1.25 x 2C	CVV-SB 1.25 x 2C	CVV-SB 1.25 x 2C
Panel color			White	White	White
Panel name(acc'y)	Panel type		PT-UUD	-	PT-UUD
	Grille type		-	PT-UUC	PT-UUC

Notes:-

1. Capacities are based on the following conditions:

- Cooling
- Indoor temp. 27°C[80.6°F]DB/ 19°C[66.2°F]WB
 - Outdoor temp. 35°C[95°F]DB/ 24°C[75.2°F]WB
 - Interconnecting piping length 7.5m
 - Level difference of zero
- Heating
- Indoor temp. 20°C[68°F]DB/ 15°C[59°F]WB
 - Outdoor temp. 7°C[44.6°F]DB/ 6°C[42.8°F]WB
 - Interconnecting piping length 7.5m
 - Level difference of zero

2. Capacities are net capacities

3. Due to our policy of innovation some specifications may be changed without prior notification

4. To be added for more available models

5. EEV : Electronic expansion valve

Conversion formula

kcal/h= kW x 860
Btu/h = kW x 3412
cfm = m³/min x 35.3
l/s = CMM x 1000/60

Type			1Way ceiling cassette (art type)			
Model		Unit	ARNU09GTUR2	ARUN09GTUC2	ARUN09GTUA2	
Cooling capacity		kW	2.8	2.8	2.8	
		kcal/h	2,400	2,400	2,400	
		Btu/h	9,600	9,600	9,600	
Heating capacity		kW	3.2	3.2	3.2	
		kcal/h	2,800	2,800	2,800	
		Btu/h	10,900	10,900	10,900	
Casing			Galvanized steel plate	Galvanized steel plate	Galvanized steel plate	
Dimensions(WxDxH)	Body	mm	860x450x132	860x450x132	860x450x132	
		inch	33.8x17.7x5.2	33.8x17.7x5.2	33.8x17.7x5.2	
	Front panel	mm	1,100x500x34	1,100x500x34	1,100x500x34	
		inch	43.3x19.7x1.3	43.3x19.7x1.3	43.3x19.7x1.3	
Coil	Rows x Columns x FPI		2x12x18	2x12x18	2x12x18	
	Face area	m ²	0.16	0.16	0.16	
Fan	Type		Cross flow fan	Cross flow fan	Cross flow fan	
	Motor output x number	W	30	30	30	
	Running current	A	0.18	0.18	0.18	
	Air flow rate(H/M/L)	CMM		9.2/8.6/8.2	9.2/8.6/8.2	9.2/8.6/8.2
		cfm		324.7/303.6/289.5	324.7/303.6/289.5	324.7/303.6/289.5
	Drive		Direct	Direct	Direct	
Motor type		BLDC	BLDC	BLDC		
Temperature control			Microprocessor, Thermostat for cooling and heating	Microprocessor, Thermostat for cooling and heating	Microprocessor, Thermostat for cooling and heating	
Sound absorbing thermal insulation material			Foamed polystyrene	Foamed polystyrene	Foamed polystyrene	
Safety device			Fuse	Fuse	Fuse	
Pipe connections	Liquid side	mm(inch)	Ø6.35(1/4)	Ø6.35(1/4)	Ø6.35(1/4)	
	Gas side	mm(inch)	Ø12.7(1/2)	Ø12.7(1/2)	Ø12.7(1/2)	
	Drain pipe(internal dia.)	mm	25	25	25	
Net weight	Body	kg(lbs)	14.6(32.2)	14(30.86)	14(30.86)	
Noise level(sound press, 1.5m, H/M/L)		dB(A)	35/34/32	35/34/32	35/34/32	
Power supply		Ø, V, Hz	1, 220 ~ 240, 50 1, 220, 60	1, 220 ~ 240, 50 1, 220, 60	1, 220 ~ 240, 50 1, 220, 60	
Refrigerant control			EEV	EEV	EEV	
Power cable			CV1.5 x 3C	CV1.5 x 3C	CV1.5 x 3C	
Transmission cable			CVV-SB 1.25 x 2C	CVV-SB 1.25 x 2C	CVV-SB 1.25 x 2C	
Panel color			White	White	White	
Panel name(acc'y)	Panel type		PT-UUD	-	PT-UUD	
	Grille type		-	PT-UUC	PT-UUC	

Notes:-

- Capacities are based on the following conditions:
 - Cooling
 - Indoor temp. 27°C[80.6°F]DB/ 19°C[66.2°F]WB
 - Outdoor temp. 35°C[95°F]DB/ 24°C[75.2°F]WB
 - Interconnecting piping length 7.5m
 - Level difference of zero
 - Heating
 - Indoor temp. 20°C[68°F]DB/ 15°C[59°F]WB
 - Outdoor temp. 7°C[44.6°F]DB/ 6°C[42.8°F]WB
 - Interconnecting piping length 7.5m
 - Level difference of zero
- Capacities are net capacities
- Due to our policy of innovation some specifications may be changed without prior notification
- To be added for more available models
- EEV : Electronic expansion valve

Conversion formula

kcal/h= kW x 860
 Btu/h = kW x 3412
 cfm = m³/min x 35.3
 l/s = CMM x 1000/60

Type			1Way ceiling cassette (art type)		
Model		Unit	ARNU12GTUR2	ARUN12GTUC2	ARUN12GTUA2
Cooling capacity		kW	3.6	3.6	3.6
		kcal/h	3,100	3,100	3,100
		Btu/h	12,300	12,300	12,300
Heating capacity		kW	4	4	4
		kcal/h	3,400	3,400	3,400
		Btu/h	13,600	13,600	13,600
Casing			Galvanized steel plate	Galvanized steel plate	Galvanized steel plate
Dimensions(WxDxH)	Body	mm	860x450x132	860x450x132	860x450x132
		inch	33.8x17.7x5.2	33.8x17.7x5.2	33.8x17.7x5.2
	Front panel	mm	1,100x500x34	1,100x500x34	1,100x500x34
		inch	43.3x19.7x1.3	43.3x19.7x1.3	43.3x19.7x1.3
Coil	Rows x Columns x FPI		2x12x18	2x12x18	2x12x18
	Face area		m ²	0.16	0.16
	Type		Cross flow fan	Cross flow fan	Cross flow fan
	Motor output x number		W	30	30
Fan	Running current		A	0.18	0.18
	Air flow rate(H/M/L)	CMM	10/9.2/8.2	10/9.2/8.2	10/9.2/8.2
		cfm	353/324.8/289.5	353/324.8/289.5	353/324.8/289.5
	Drive		Direct	Direct	Direct
	Motor type		BLDC	BLDC	BLDC
Temperature control			Microprocessor, Thermostat for cooling and heating	Microprocessor, Thermostat for cooling and heating	Microprocessor, Thermostat for cooling and heating
Sound absorbing thermal insulation material			Foamed polystyrene	Foamed polystyrene	Foamed polystyrene
Safety device			Fuse	Fuse	Fuse
Pipe connections	Liquid side	mm(inch)	Ø6.35(1/4)	Ø6.35(1/4)	Ø6.35(1/4)
	Gas side	mm(inch)	Ø12.7(1/2)	Ø12.7(1/2)	Ø12.7(1/2)
	Drain pipe(internal dia.)	mm	25	25	25
Net weight	Body	kg(lbs)	14.6(32.2)	14(30.86)	14(30.86)
Noise level(sound press, 1.5m, H/M/L)		dB(A)	38/35/32	38/35/32	38/35/32
Power supply		Ø, V, Hz	1, 220 ~ 240, 50 1, 220, 60	1, 220 ~ 240, 50 1, 220, 60	1, 220 ~ 240, 50 1, 220, 60
Refrigerant control			EEV	EEV	EEV
Power cable			CV1.5 x 3C	CV1.5 x 3C	CV1.5 x 3C
Transmission cable			CVV-SB 1.25 x 2C	CVV-SB 1.25 x 2C	CVV-SB 1.25 x 2C
Panel color			White	White	White
Panel name(acc'y)	Panel type		PT-UUD	-	PT-UUD
	Grille type		-	PT-UUC	PT-UUC

Notes:-

1. Capacities are based on the following conditions:

- Cooling
 - Indoor temp. 27°C[80.6°F]DB/ 19°C[66.2°F]WB
 - Outdoor temp. 35°C[95°F]DB/ 24°C[75.2°F]WB
 - Interconnecting piping length 7.5m
 - Level difference of zero
- Heating
 - Indoor temp. 20°C[68°F]DB/ 15°C[59°F]WB
 - Outdoor temp. 7°C[44.6°F]DB/ 6°C[42.8°F]WB
 - Interconnecting piping length 7.5m
 - Level difference of zero

2. Capacities are net capacities

3. Due to our policy of innovation some specifications may be changed without prior notification

4. To be added for more available models

5. EEV : Electronic expansion valve

Conversion formula

kcal/h= kW x 860
 Btu/h = kW x 3412
 cfm = m³/min x 35.3
 l/s = CMM x 1000/60

Type			1Way ceiling cassette (art type)		
Model		Unit	ARNU18GTTR2	ARUN18GTTC2	ARUN18GTTA2
Cooling capacity		kW	5.6	5.6	5.6
		kcal/h	4,800	4,800	4,800
		Btu/h	19,100	19,100	19,100
Heating capacity		kW	6.3	6.3	6.3
		kcal/h	5,400	5,400	5,400
		Btu/h	21,500	21,500	21,500
Casing			Galvanized steel plate	Galvanized steel plate	Galvanized steel plate
Dimensions(WxDxH)	Body	mm	1,180x450x132	1,180x450x132	1,180x450x132
		inch	46.5x17.7x5.2	46.5x17.7x5.2	46.5x17.7x5.2
	Front panel	mm	1,420x500x34	1,420x500x34	1,420x500x34
		inch	55.9x19.7x1.3	55.9x19.7x1.3	55.9x19.7x1.3
Coil	Rows x Columns x FPI		2x12x18	2x12x18	2x12x18
	Face area		m ²	0.24	0.24
	Type		Cross flow fan	Cross flow fan	Cross flow fan
	Motor output x number		W	30	30
Fan	Running current		A	0.3	0.3
	Air flow rate(H/M/L)	CMM	13.3/12.1/10.9	13.3/12.1/10.9	13.3/12.1/10.9
		cfm	515.4/427.1/384.8	515.4/427.1/384.8	515.4/427.1/384.8
	Drive		Direct	Direct	Direct
Motor type		BLDC	BLDC	BLDC	
Temperature control			Microprocessor, Thermostat for cooling and heating	Microprocessor, Thermostat for cooling and heating	Microprocessor, Thermostat for cooling and heating
Sound absorbing thermal insulation material			Foamed polystyrene	Foamed polystyrene	Foamed polystyrene
Safety device			Fuse	Fuse	Fuse
Pipe connections	Liquid side	mm(inch)	Ø6.35(1/4)	Ø6.35(1/4)	Ø6.35(1/4)
	Gas side	mm(inch)	Ø12.7(1/2)	Ø12.7(1/2)	Ø12.7(1/2)
	Drain pipe(internal dia.)	mm	25	25	25
Net weight	Body	kg(lbs)	18.6(41)	18(39.68)	18(39.68)
Noise level(sound press, 1.5m, H/M/L)		dB(A)	40/37/35	40/37/35	40/37/35
Power supply		Ø, V, Hz	1, 220 ~ 240, 50 1, 220, 60	1, 220 ~ 240, 50 1, 220, 60	1, 220 ~ 240, 50 1, 220, 60
Refrigerant control			EEV	EEV	EEV
Power cable			CV1.5 x 3C	CV1.5 x 3C	CV1.5 x 3C
Transmission cable			CVV-SB 1.25 x 2C	CVV-SB 1.25 x 2C	CVV-SB 1.25 x 2C
Panel color			White	White	White
Panel name(acc'y)	Panel type		PT-UTD	-	PT-UTD
	Grille type		-	PT-UTC	PT-UTC

Notes:-

- Capacities are based on the following conditions:
 - Cooling
 - Indoor temp. 27°C[80.6°F]DB/ 19°C[66.2°F]WB
 - Outdoor temp. 35°C[95°F]DB/ 24°C[75.2°F]WB
 - Interconnecting piping length 7.5m
 - Level difference of zero
 - Heating
 - Indoor temp. 20°C[68°F]DB/ 15°C[59°F]WB
 - Outdoor temp. 7°C[44.6°F]DB/ 6°C[42.8°F]WB
 - Interconnecting piping length 7.5m
 - Level difference of zero
- Capacities are net capacities
- Due to our policy of innovation some specifications may be changed without prior notification
- To be added for more available models
- EEV : Electronic expansion valve

Conversion formula

kcal/h= kW x 860
 Btu/h = kW x 3412
 cfm = m³/min x 35.3
 l/s = CMM x 1000/60

Type			1Way ceiling cassette (art type)			
Model		Unit	ARNU24GTTR2	ARUN24GTT*2	ARUN24GTT*2	
Cooling capacity		kW	7.1	7.1	7.1	
		kcal/h	6,100	6,100	6,100	
		Btu/h	24,200	24,200	24,200	
Heating capacity		kW	7.1	7.1	7.1	
		kcal/h	6,100	6,100	6,100	
		Btu/h	24,200	24,200	24,200	
Casing			Galvanized steel plate	Galvanized steel plate	Galvanized steel plate	
Dimensions(WxDxH)	Body	mm	1,180x450x132	1,180x450x132	1,180x450x132	
		inch	46.5x17.7x5.2	46.5x17.7x5.2	46.5x17.7x5.2	
	Front panel	mm	1,420x500x34	1,420x500x34	1,420x500x34	
		inch	55.9x19.7x1.3	55.9x19.7x1.3	55.9x19.7x1.3	
Coil	Rows x Columns x FPI		2x12x18	2x12x18	2x12x18	
	Face area	m ²	0.24	0.24	0.24	
Fan	Type		Cross flow fan	Cross flow fan	Cross flow fan	
	Motor output x number	W	30	30	30	
	Running current	A	0.3	0.3	0.3	
	Air flow rate(H/M/L)	CMM		14.6/13.3/11.5	14.6/13.3/11.5	14.6/13.3/11.5
		cfm		515.4/469.5/406	515.4/469.5/406	515.4/469.5/406
	Drive		Direct	Direct	Direct	
Motor type		BLDC	BLDC	BLDC		
Temperature control			Microprocessor, Thermostat for cooling and heating	Microprocessor, Thermostat for cooling and heating	Microprocessor, Thermostat for cooling and heating	
Sound absorbing thermal insulation material			Foamed polystrene	Foamed polystrene	Foamed polystrene	
Safety device			Fuse	Fuse	Fuse	
Pipe connections	Liquid side	mm(inch)	Ø9.52(3/8)	Ø9.52(3/8)	Ø9.52(3/8)	
	Gas side	mm(inch)	Ø15.88(5/8)	Ø15.88(5/8)	Ø15.88(5/8)	
	Drain pipe(internal dia.)	mm	25	25	25	
Net weight	Body	kg(lbs)	18.6(41)	18(39.68)	18(39.68)	
Noise level(sound press, 1.5m, H/M/L)		dB(A)	43/40/36	43/40/36	43/40/36	
Power supply		Ø, V, Hz	1, 220 ~ 240, 50 1, 220, 60	1, 220 ~ 240, 50 1, 220, 60	1, 220 ~ 240, 50 1, 220, 60	
Refrigerant control			EEV	EEV	EEV	
Power cable			CV1.5 x 3C	CV1.5 x 3C	CV1.5 x 3C	
Transmission cable			CVV-SB 1.25 x 2C	CVV-SB 1.25 x 2C	CVV-SB 1.25 x 2C	
Panel color			White	White	White	
Panel name(acc'y)	Panel type		PT-UTD	-	PT-UTD	
	Grille type		-	PT-UTC	PT-UTC	

Notes:-

- Capacities are based on the following conditions:
 - Cooling
 - Indoor temp. 27°C[80.6°F]DB/ 19°C[66.2°F]WB
 - Outdoor temp. 35°C[95°F]DB/ 24°C[75.2°F]WB
 - Interconnecting piping length 7.5m
 - Level difference of zero
 - Heating
 - Indoor temp. 20°C[68°F]DB/ 15°C[59°F]WB
 - Outdoor temp. 7°C[44.6°F]DB/ 6°C[42.8°F]WB
 - Interconnecting piping length 7.5m
 - Level difference of zero

- Capacities are net capacities
- Due to our policy of innovation some specifications may be changed without prior notification
- To be added for more available models
- EEV : Electronic expansion valve

Conversion formula
kcal/h= kW x 860
Btu/h = kW x 3412
cfm = m ³ /min x 35.3
l/s = CMM x 1000/60

2. List of Functions

* Model Name
R:Robot, C:Plasma, A:Basic

Category	Function	ARNU24GTT*2 / ARNU18GTT*2 / ARNU12GTU*2 / ARNU09GTU*2 / ARNU07GTU*2
Air flow	Air supply outlet	1
	Airflow direction control(left & right)	0
	Airflow direction control(up & down)	0
	Auto swing(left & right)	0
	Auto swing(up & down)	0
	Airflow steps(fan/cool/heat)	4/5/4
	Chaos swing	0
	Chaos wind(auto wind)	0
	Jet cool(power wind)	0
	Swirl wind	-
Air purifying	Deodorizing filter	X
	Plasma air purifier	Option
	Pre-filter(washable / anti-fungus)	Option
	Robot cleaner	Option
Installation	Drain pump	0
	E.S.P. control	0
	Electric heater(operation)	X
	High ceiling operation	0
Reliability	Hot start	0
	Self diagnosis	0
	Soft dry operation	0
Convenience	Auto changeover	0(Heat recovery)
	Auto cleaning	0
	Auto operation(artificial intelligence)	0(Heat pump or cooling only)
	Auto restart operation	0
	Child lock	0
	Forced operation	0
	Group control	0
	Sleep mode	0
	Timer(on/off)	0
	Timer(weekly)	0
	Two thermistor control	0
Elevation grill (accessory)	x	
Individual control	Standard wired remote controller	Accessory
	Deluxe wired remote controller	Accessory
	Simple wired remote controller	Accessory
	Wired remote controller(for hotel use)	Accessory
	Wireless remote controller(simple)	X
	Wireless LCD remote control	Accessory
Special function kit	Zone control	-
	CTIE	-
	Electro thermostat	-

O : Applied X : Not applied - : No relation

Option : Model name & price are different according to options, and assembled in factory with main unit.

Accessory : Installed at field, ordered and purchased separately by the corresponding model name, supplied with separate package.

3. Piping Diagrams

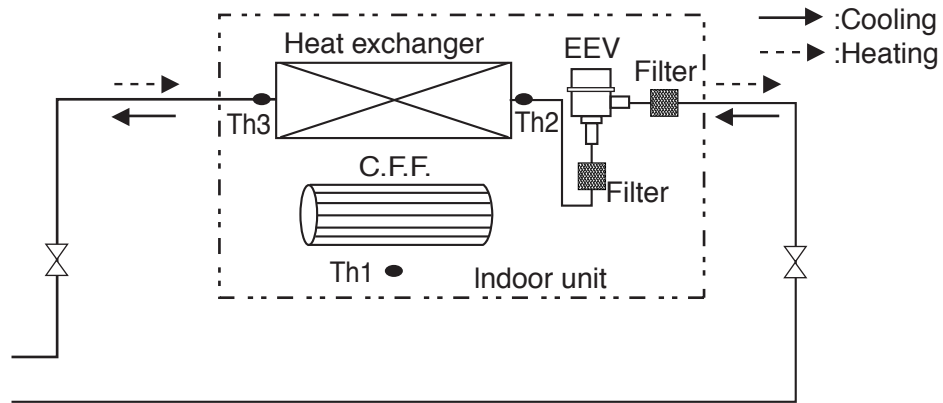

■ Refrigerant pipe connection port diameter

[Unit: mm(inch)]

Model	Gas	Liquid
ARNU07GTU*2	Ø12.7(1/2)	Ø6.35(1/4)
ARNU09GTU*2	Ø12.7(1/2)	Ø6.35(1/4)
ARNU12GTU*2	Ø12.7(1/2)	Ø6.35(1/4)
ARNU18GTT*2	Ø12.7(1/2)	Ø6.35(1/4)
ARNU24GTT*2	Ø15.88(5/8)	Ø9.52(3/8)

* Model Name

R:Robot, C:Plasma, A:Basic

LOC.	Description
Th1	Room thermistor
Th2	Pipe in thermistor
Th3	Pipe out thermistor

4. Wiring Diagrams

Robot model : ARNU**GT*R2

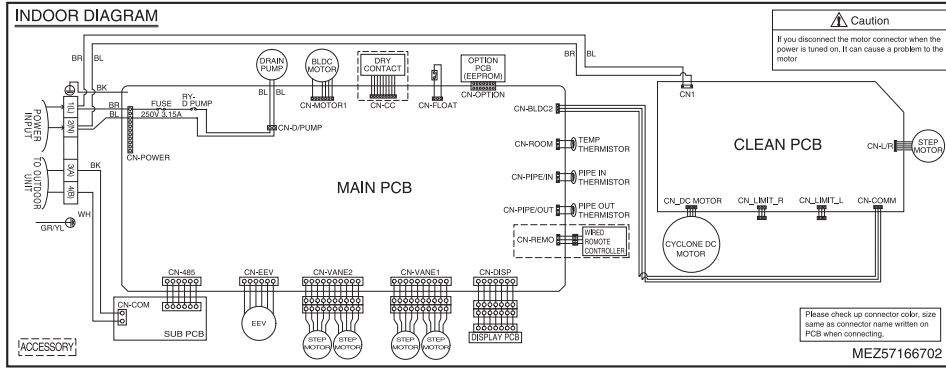

Plasma / Standard model : ARNU**GT*C2/A2

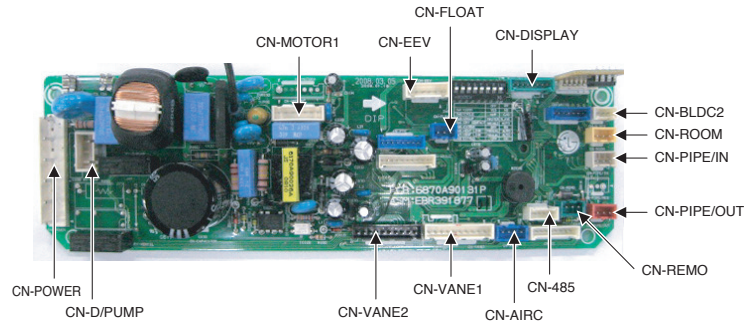
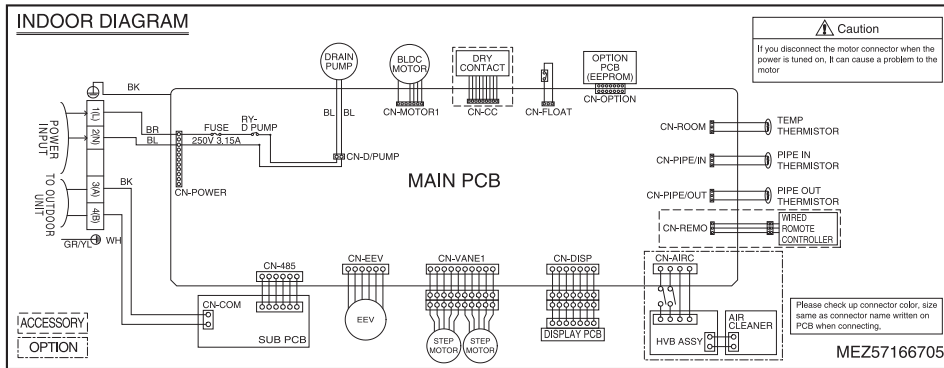

Dip switch setting	Off	On	Remarks
SW3 Group	Master	Slave	Group control setting using wired remote controller
SW4 Dry contact	Variable	Auto	Dry contact mode setting 1. Variable : Auto/manual mode can be chosen by wide wired remote controller or wireless remote controller (when shipped from factory → manual mode) 2. Auto : For dry contact, it is always auto mode.
SW5 Extra 1	Off	On	1. Duct model - Off : Default(not operate continuously) - On : Fan operate continuously 2. Cassette model : No function 3. Ceiling suspended model - Off : Ceiling(default) - On : Floor

CAUTION

For Multi V model, dip switch 1,2,6,7,8 must be set off. Those dip switches are used for other models.

5. Exploded View

• TT chassis : Robot model (ARNU**GTTR2)

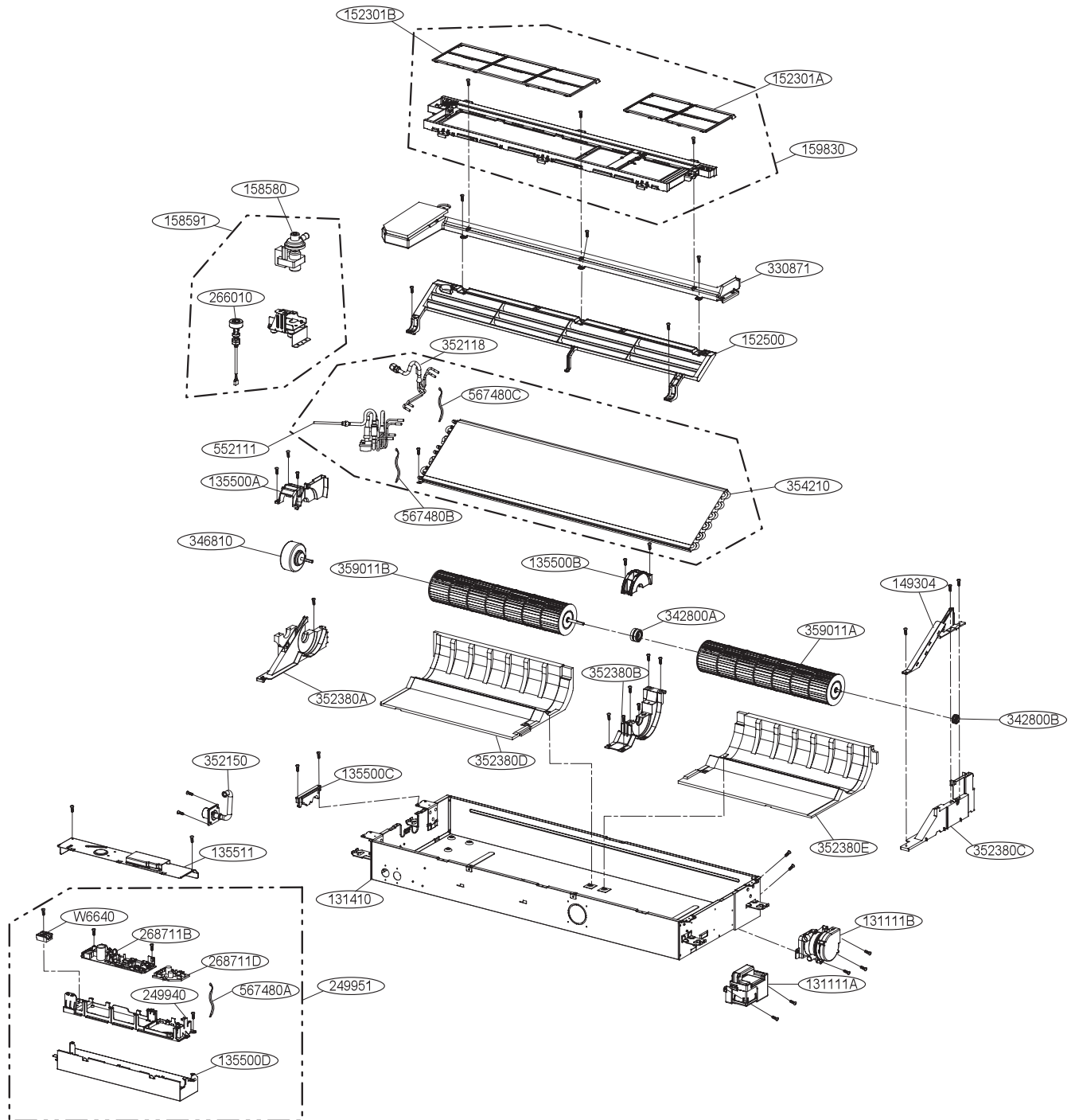

Thermistor 1	567480A	Air	Housing color : yellow
Thermistor 2	567480B	Pipe in	Housing color : white
Thermistor 3	567480C	Pipe out	Housing color : red

5. Exploded View

• TT chassis : Plasma model (ARNU**GTTC2)

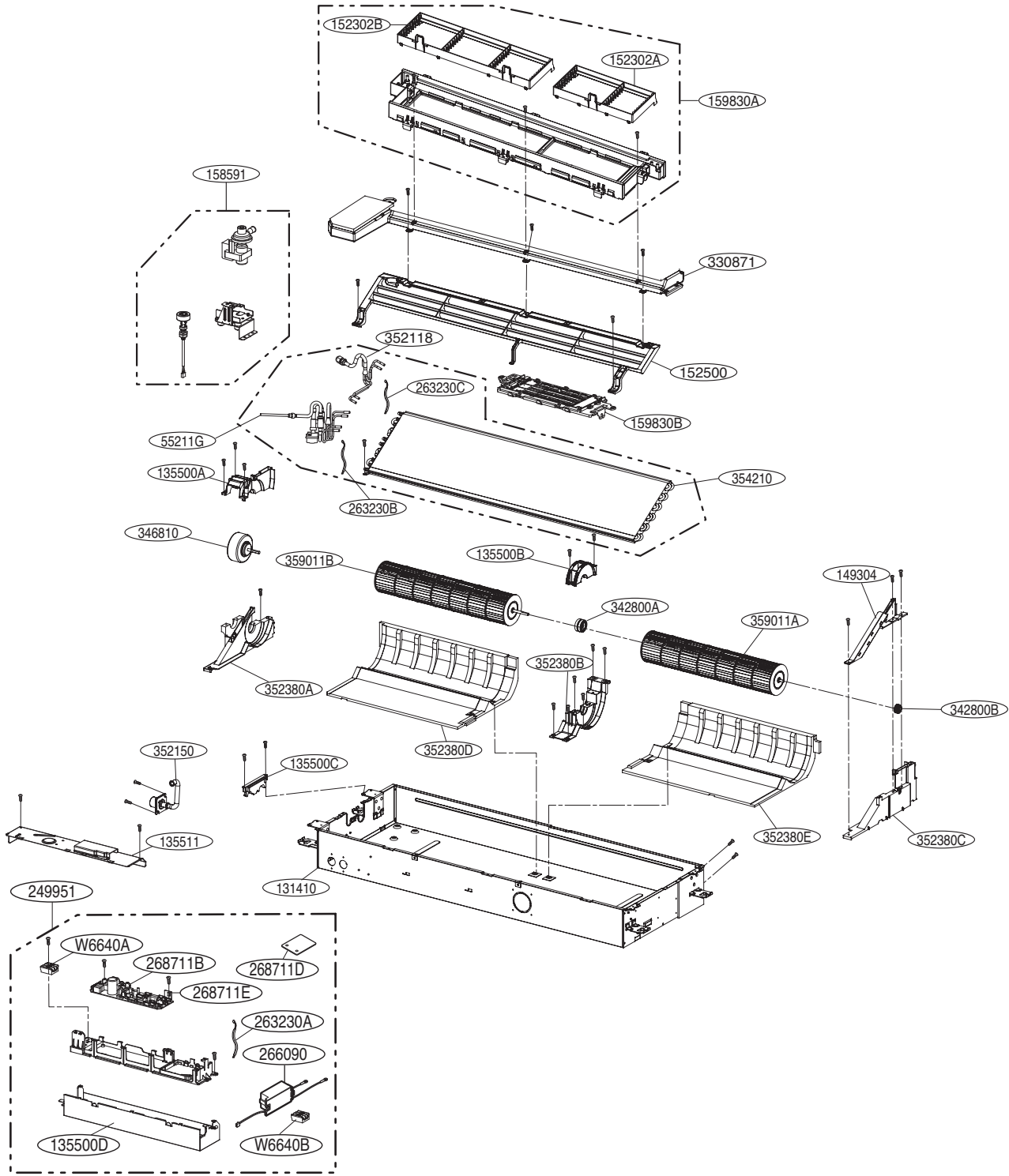

Thermistor 1	263230A	Air	Housing color : yellow
Thermistor 2	263230B	Pipe in	Housing color : white
Thermistor 3	263230C	Pipe out	Housing color : red

5. Exploded View

• TT chassis : Standard model (ARNU**GTTA2)

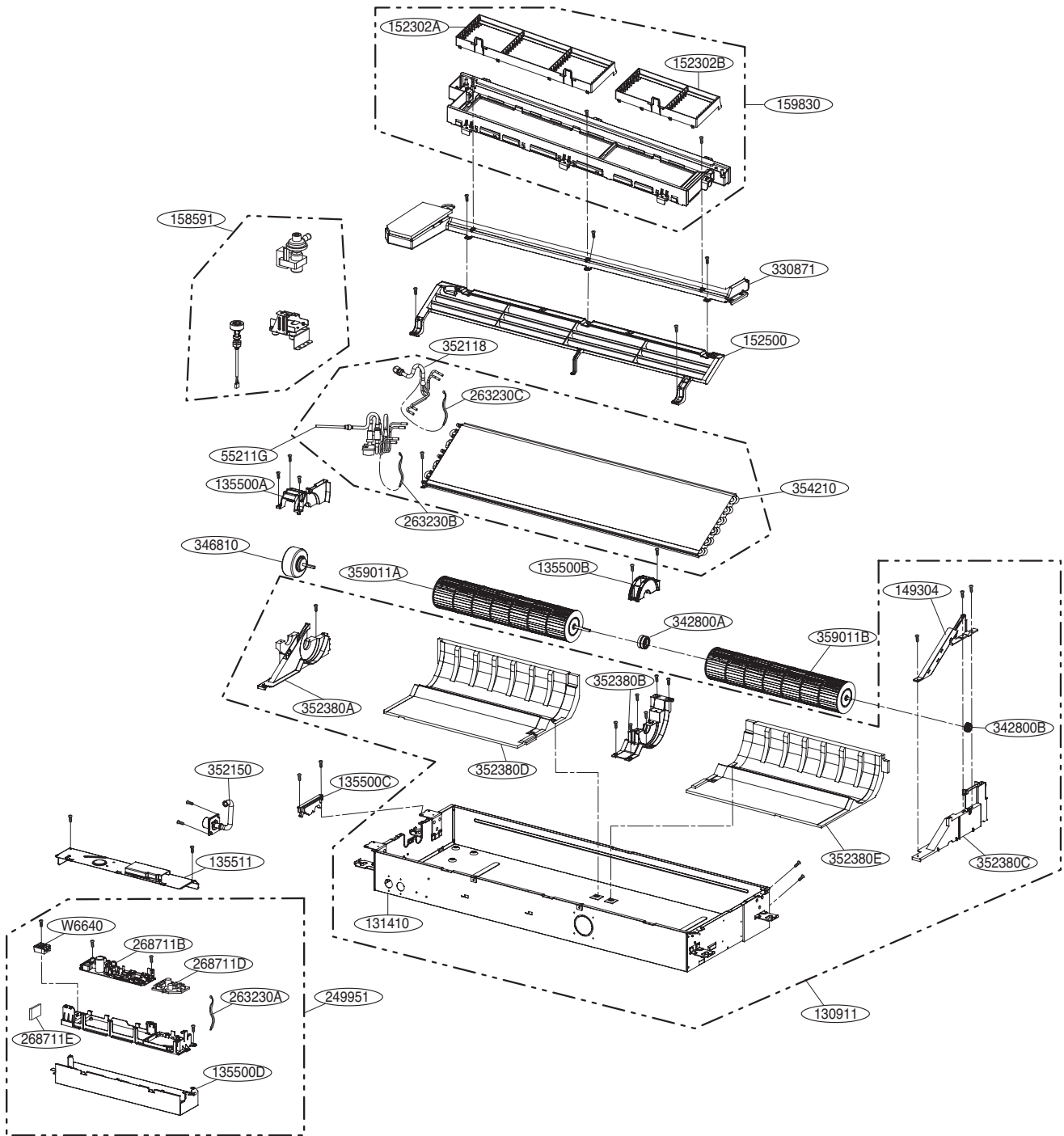

Thermistor 1	263230A	Air	Housing color : yellow
Thermistor 2	263230B	Pipe in	Housing color : white
Thermistor 3	263230C	Pipe out	Housing color : red

5. Exploded View

TT chassis front panel (panel type) : PT-UTD

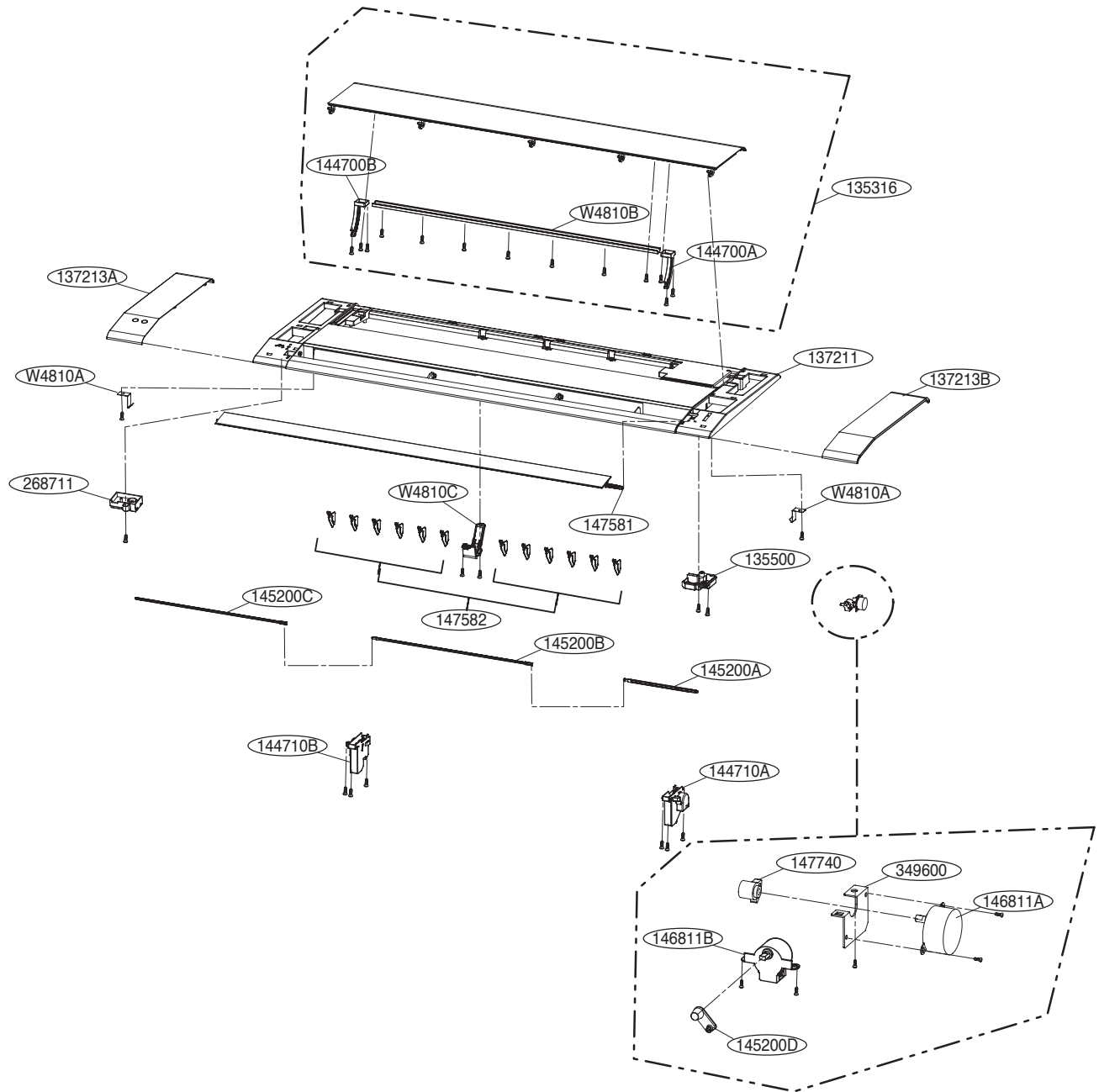

5. Exploded View

TT chassis front panel (grille type) : PT-UTC

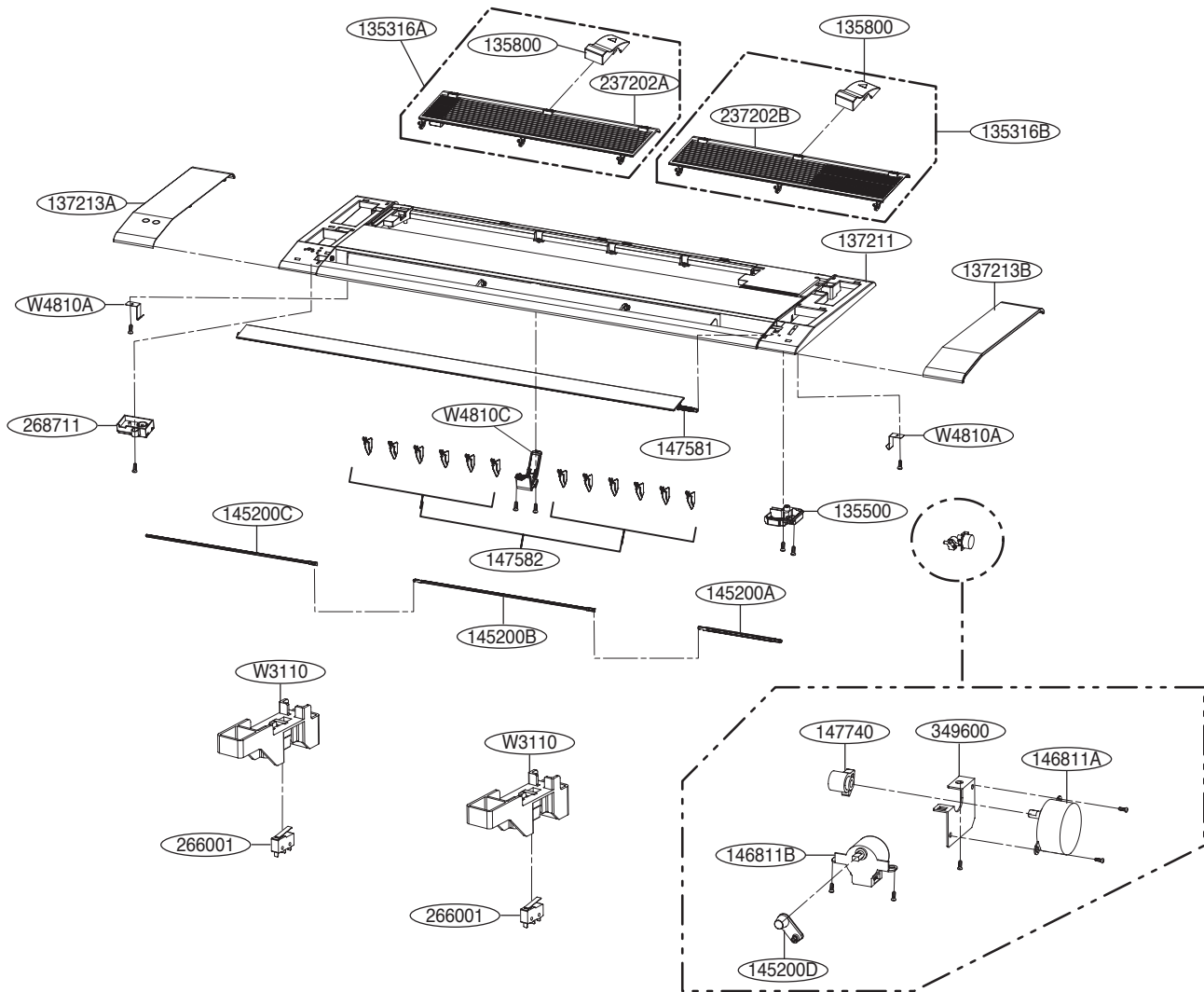

5. Exploded View

• TU chassis : Robot model (ARNU**GTUR2)

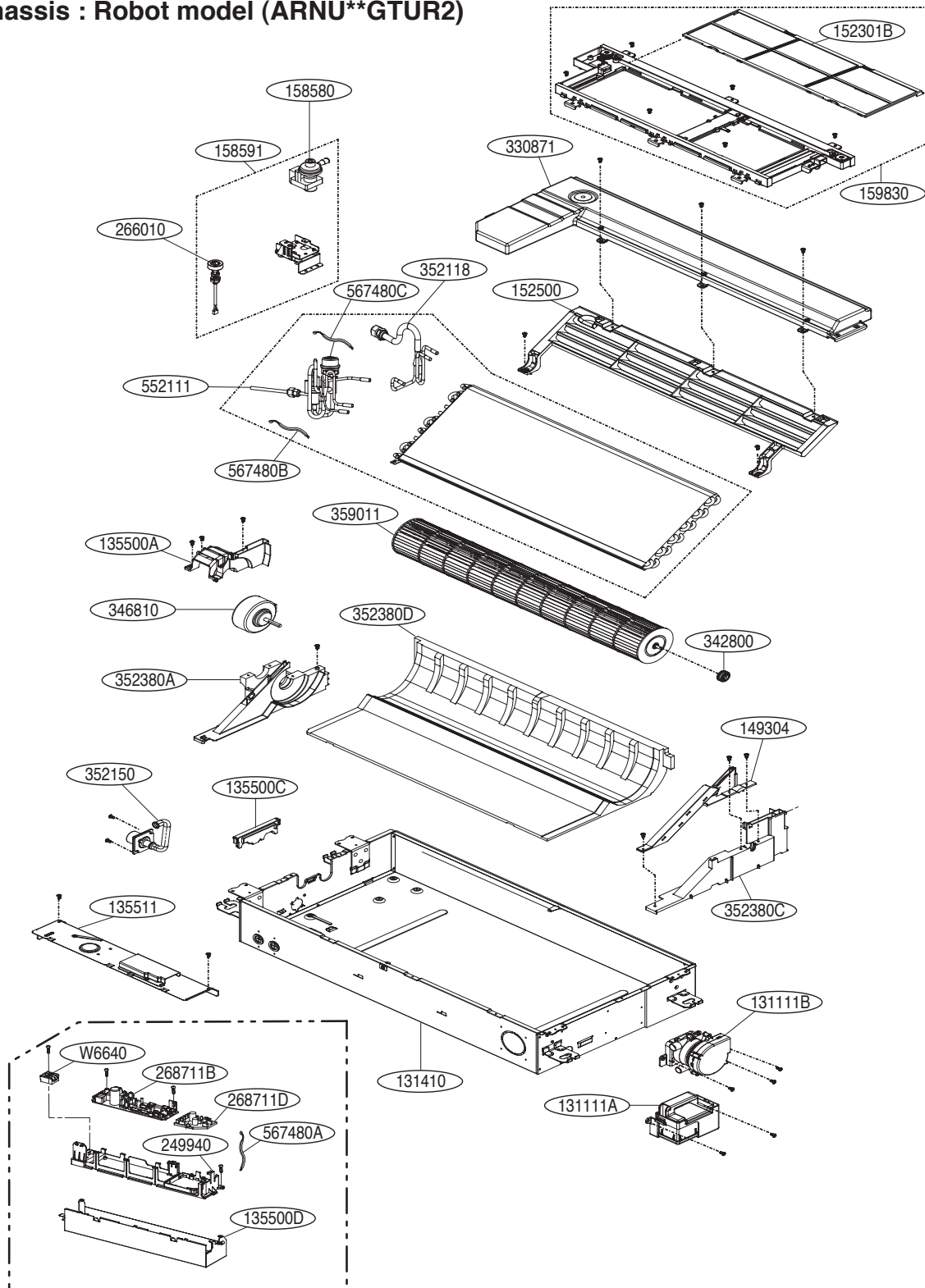

Thermistor 1	567480A	Air	Housing color : yellow
Thermistor 2	567480B	Pipe in	Housing color : white
Thermistor 3	567480C	Pipe out	Housing color : red

5. Exploded View

• TU chassis : Plasma model (ARNU**GTUC2)

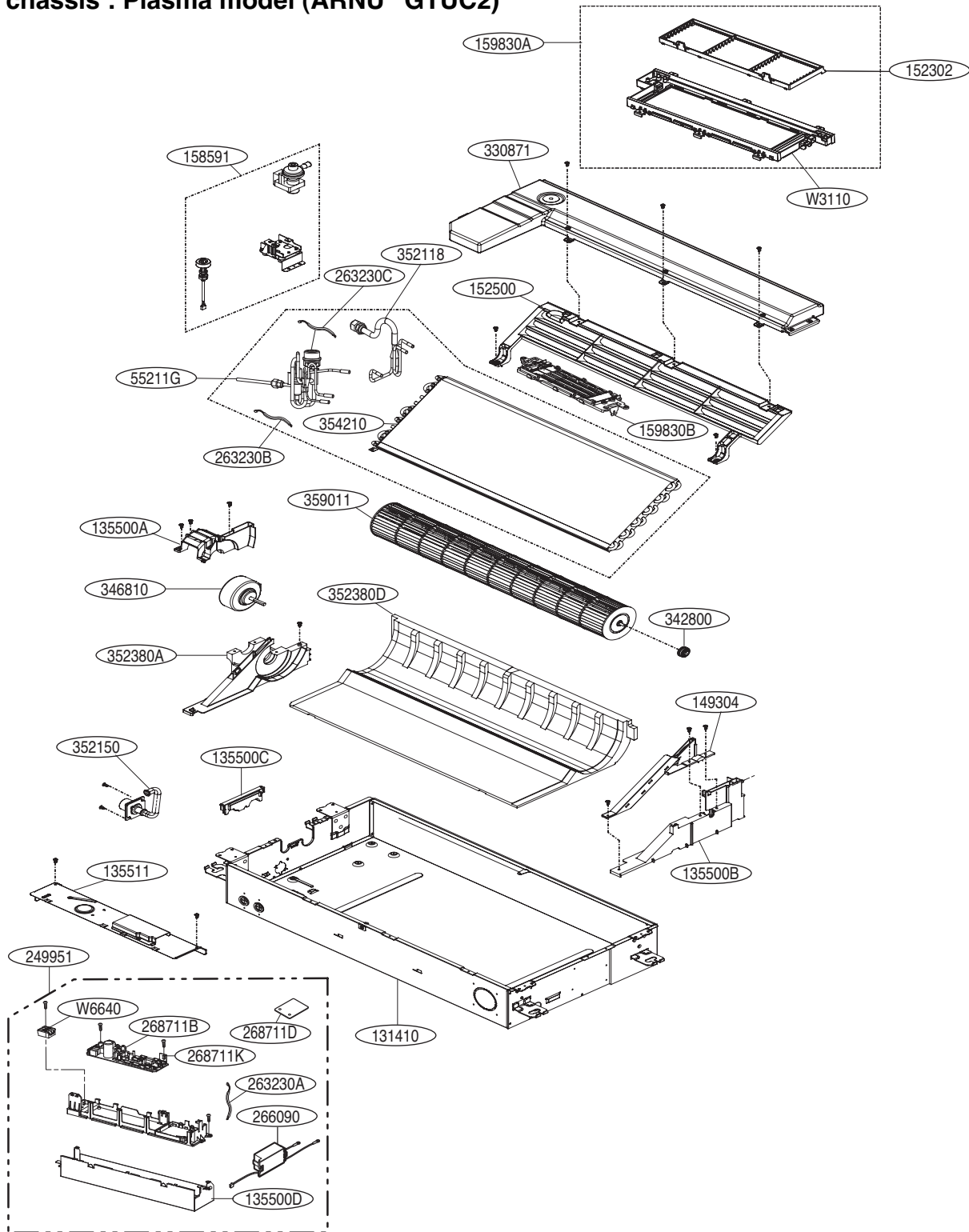

Thermistor 1	263230A	Air	Housing color : yellow
Thermistor 2	263230B	Pipe in	Housing color : white
Thermistor 3	263230C	Pipe out	Housing color : red

5. Exploded View

• TU chassis : Standard model (ARNU**GTUA2)

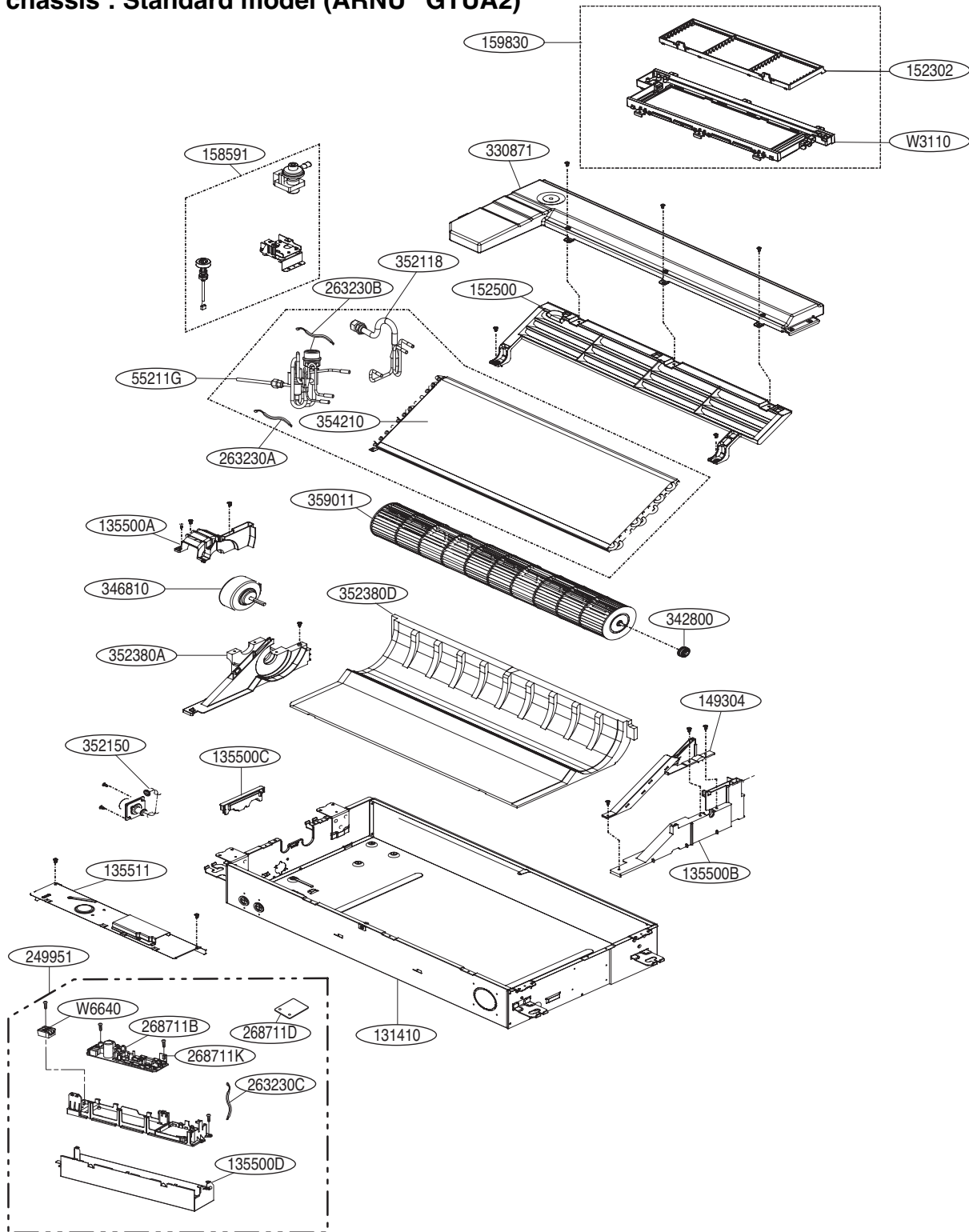

Thermistor 1	263230C	Air	Housing color : yellow
Thermistor 2	263230A	Pipe in	Housing color : white
Thermistor 3	263230B	Pipe out	Housing color : red

5. Exploded View

TU chassis : Front panel (panel type) : PT-UUD

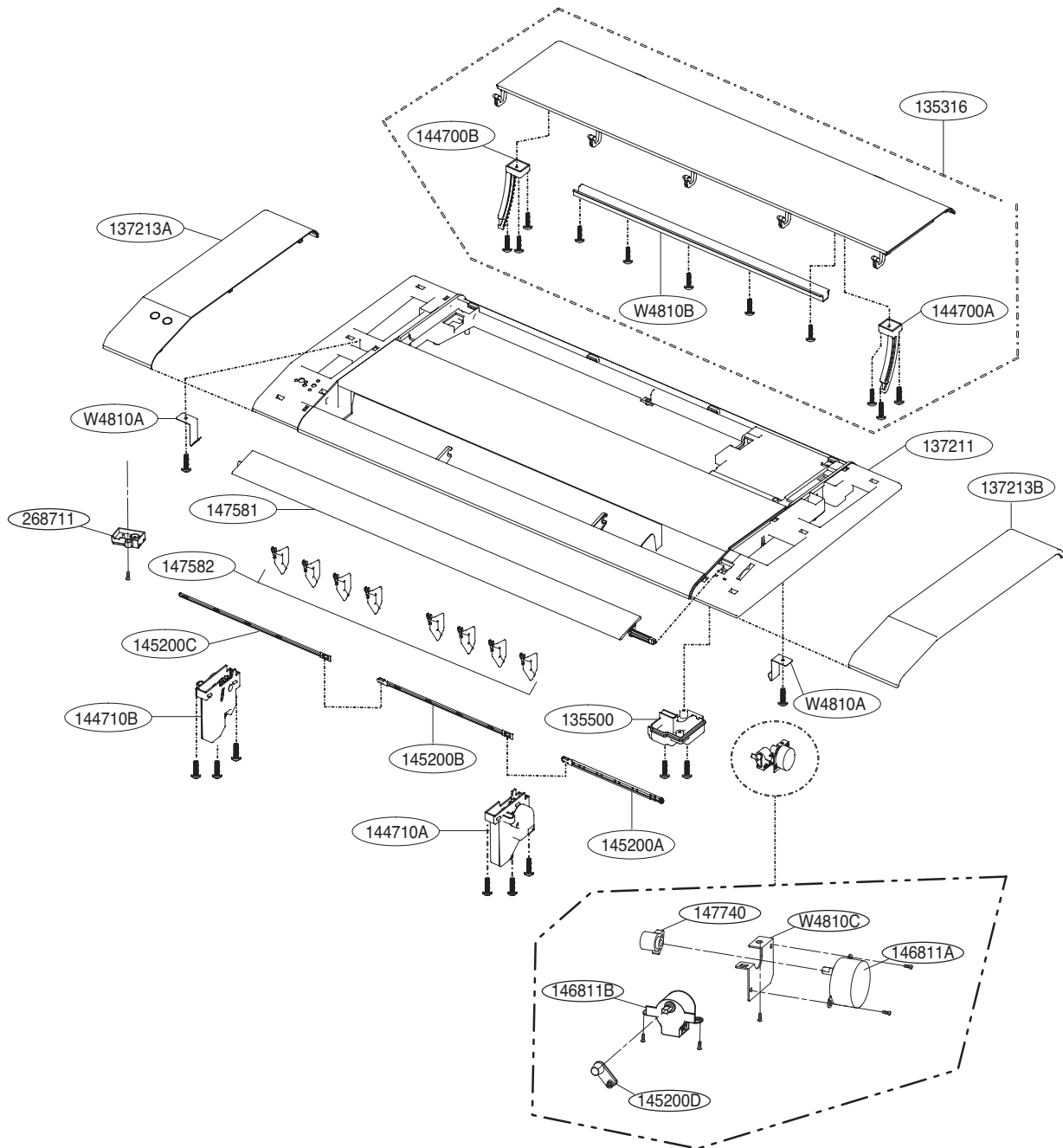

Thermistor 1	567480A	Air	Housing color : yellow
Thermistor 2	567480B	Pipe in	Housing color : white
Thermistor 3	567480C	Pipe out	Housing color : red

5. Exploded View

TU chassis : Front panel (grille type) : PT-UUC

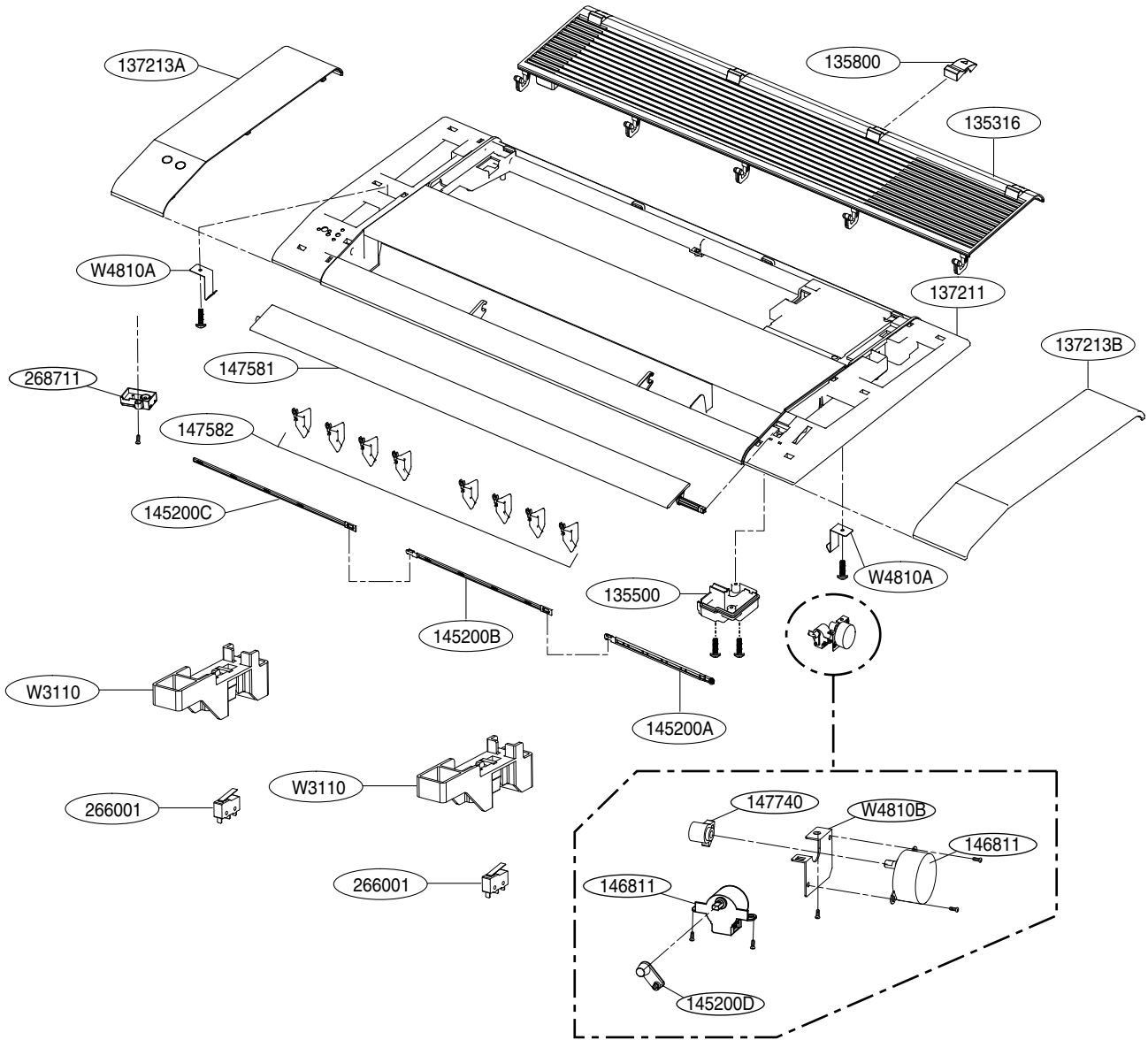



P/NO : MFL57199202

DECEMBER, 2009